

TeKnol Ltd.
79-2, Warshavskoe shosse
117556 Moscow,
RUSSIA

e-mail: contact@teknol.ru
<http://www.teknol.ru>



Autonomous Portable Glass Cockpit System (PGC-A)

SYSTEM SPECIFICATION

December 2008

1 System structure

The PGC-A system consists of the following units:

- MEMS/GNSS integrated navigation system “CompaNav-2”
- Tablet PC Panasonic CF-19
- Commutation unit
- GPS receiver Garmin 35
- Commutation cables

2 Navigation system “CompaNav-2”

“CompaNav-2” is an inertial/GNSS integrated navigation system based on MEMS sensors. The system provides 50 Hz output of position coordinates (latitude, longitude and height), attitude angles (pitch, roll and heading), accelerations and angular velocities with respect to local level frame.

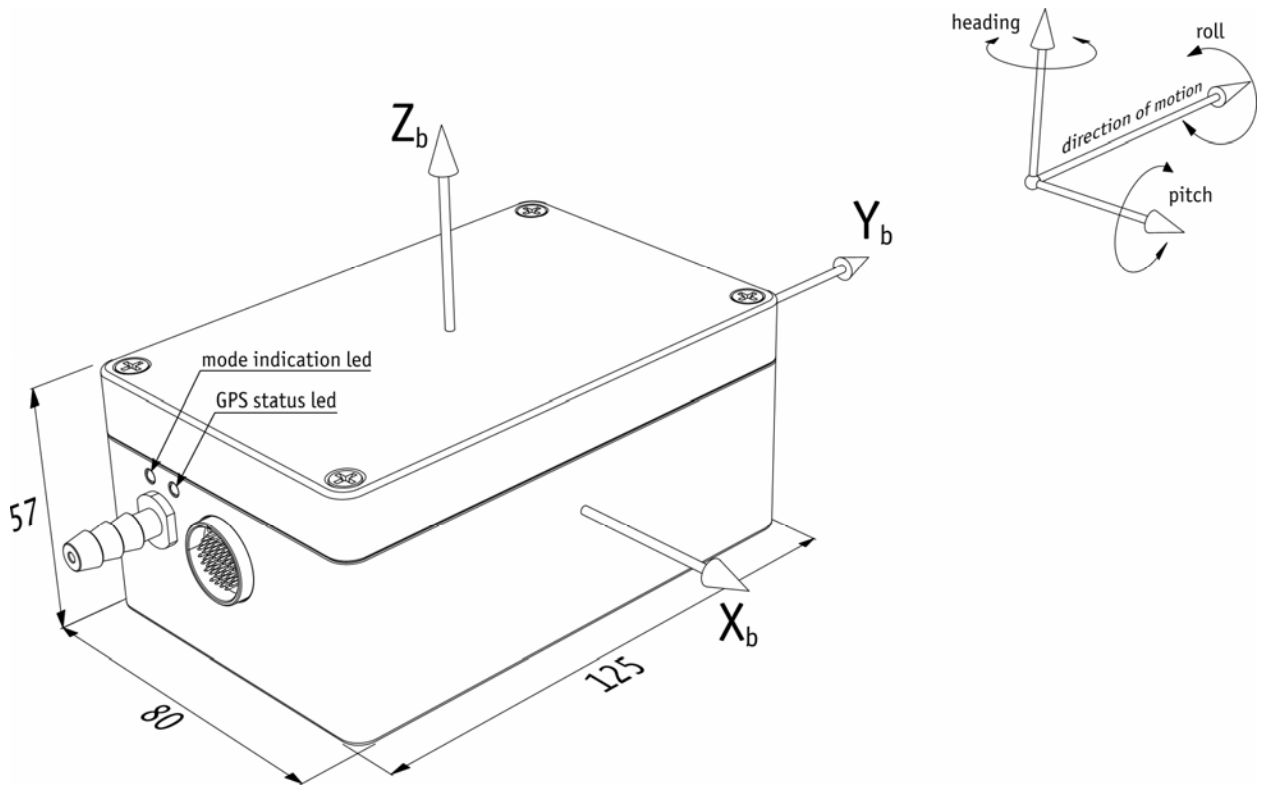

Figure 1

2.1.1 Technical specification

Physical		
Size	in	4,9x3,1x2,2
	cm	12,5x8,0x5,7
Weight	lbs	1,4
	kg	0,6
Environmental		
Operating temperature	deg C	-40 to +85
Non-operating temperature	deg C	-60 to +85
Humidity	%	<98
Atmospheric pressure	kPa	20-113
Operating vibration (50-2000 Hz, sine)	g RMS	±4
Shock (11msec)	g	40
Electrical		
Input voltage	VDC	10-30
Input current (at 12 VDC)	A	0,17
Power consumption (at 12 VDC)	W	<1,5
Data		
Update rate	Hz	50
Fully stabilized data	sec	30
Output signal type		RS-232
Data format		proprietary binary

2.1.2 Dynamic ranges

		Range	Resolution
Roll, Pitch	deg	±180, ±90	0,05
Accelerations	g	±6	10 ⁻³
Heading	deg	0...360	0,1
Angular rate	deg/sec	± 300	10 ⁻²
Max. calibrated altitude (for barometric altimeter)	m	6,000	0,2
	ft	18,000	1

2.1.3 Accuracy

	Units	GNSS On	GNSS Gap 5 min	GNSS Off
Position	m RMS	6 (*)	500 (**)	Not available
Velocity				
X,Y Velocity	m/s RMS	0,2	5 (**)	Not available
Z Velocity	m/s RMS	0,25	0,3	0,5
Pitch and Roll				
Straight Horizontal Flight	deg RMS	0,2...0,3	0,2...0,3	0,3...0,4
Normal Manoeuvre (***)	deg RMS	0,3...0,5	0,5...0,7	0,5...0,7
Complex Manoeuvre (***)	deg RMS	1,3	1,5	2
Heading (****)	deg RMS	0,4	4	Not available
Altitude	m	2	2...4	6

Notes

(*)Applies to a configuration with GPS receiver Garmin GPS35 (positioning accuracy of 15 m RMS).

(**) Assumes straight level flight prior to and during GPS gap.

(***) Normal is "pitch and roll less 45 deg", complex is "pitch and roll 45 deg...75 deg".

(****) Heading is calculated as deviation from the tracking angle value which is output by GNSS receiver immediately after CompaNav-2 initialization.

3 Panasonic CF-19



Panasonic CF-19 is a ruggedized tablet PC certified under MIL-STD-810F standard with high-brightness LCD with Circular Polarizing Touch Screen and anti-reflection coating for easy viewing under direct sunlight.

Technical specification

Processor	Intel Core Duo 1,06 GHz
HDD	80 Gb
RAM	1,5 Gb
Interface	USB port (4-pin, USB 2.0)× 2, Serial Port (Dsub 9-pin male), Modem port (RJ-11), LAN port (RJ-45), External display port (Mini Dsub 15-pin female), Expansion Bus Connector (Dedicated 100-pin female), External Antenna Connector (Dedicated 50 Ω coaxial connector)) × 2, IEEE 1394a Interface Connector, Microphone Jack, Headphone Jack
Weight	2,3 kg
Power	60 W
Display	10,4" touch screen
LCD brightness	500 nit
Operating temperature	0..+60°C
Storage temperature	Storage temperature -40..+60°C

4 Commutation unit



Commutation unit provides data and power interconnection between PGC-A units. If necessary, the unit is capable to provide 2,5 hour autonomous power supply for the whole PGC-A system.

Technical specification

	Units	Value
Size	mm	205x235x78
Weight	kg	3,7
Input voltage	VDC	17..36
Inbuilt battery capacity	A/h	1,3
Inbuilt battery charging rate	mA	320

5 Garmin GPS 35



The GARMIN GPS 35 is a single construction integrated GPS antenna/receiver. GPS35 tracks up to 12 satellites at a time, provides fast time-to-first-fix and 1Hz navigation updates. It is housed into water-resistant case and designed to withstand rugged operating conditions.

For more details please refer to Garmin GPS 35 specification.

5.1.1 Technical specification

	Units	Value
Size	mm	57x97x27
Weight	kg	0,124 (not including cable)
Operating temperature	°C	-30..+85
Storage temperature	°C	-40..+90°C
Dynamics		999 knot, 6g

5.1.2 Performance

Acquisition time	45 sec (cold start)
Velocity accuracy	0,2 m/s (RMS)
Position	15 m